

Models:

- ▶ CBS-2041
- ▶ CBS-2042



NOTICE TO INSTALLER: This book contains important programming instructions that will be needed by the customer. Please leave it with the manager or responsible person at the machine location.



Table of Contents

Contact Information	2	Temperature Settings	10
Description & Features	2	Advanced Settings and Diagnostics	10
Specifications.....	2	Relay Test.....	11
Requirements.....	2	Error Codes	12
Electrical Configuration and Brewing Efficiency .	3	Service.....	13
Dimensions & Utility Connections.....	4	Cleaning & Maintenance	13
Installation.....	5	Wiring Diagrams	14
Operating Instructions	8	Parts	16
Programming	9		
Batch Settings	9		

FETCO®, LUXUS®, and EXTRACTOR™ are trademarks or trade names of Food Equipment Technologies Company.

Contact Information

FETCO

Food Equipment Technologies Company
640 Heathrow Drive
Lincolnshire • IL • 60069 • USA

Internet: www.fetco.com

Phone: (800) 338-2699 (US & Canada)
(847) 719-3000
Fax: (847) 821-1178

Emergency Service Only: (800) 660-0035 (U.S. & Canada)

Email: sales@fetco.com
techsupport@fetco.com

Description & Features

The CBS-2041 and CBS-2042 feature our patented intermittent spray over technology, which works like this:

The following variables are programmed for each batch size:

- ❖ Brew volume
- ❖ Brew time
- ❖ Bypass percent
(Percentage of the brew volume)
- ❖ Prewet percent (Percentage of the brew volume)
- ❖ Prewet delay (The time between prewetting and the brew cycle.)
- ❖ Drip delay (The time between the end of the brew cycle and the unlocking of the brew basket.)

Using these variables, the software calculates how much water to use for prewetting, bypass, and brewing. The total brew time is divided into several 30 second cycles. Within these cycles, the software calculates how long to spray water over the coffee grounds, and how long to pause before the next cycle begins. The bypass valve opens at the beginning of the brew cycle and dispenses the correct amount of water all at once.

Features

- ❖ Two fully programmable batch sizes per side
 - ❖ Adjustable prewetting cycle
 - ❖ Adjustable bypass
 - ❖ Electronically controlled hot water service
 - ❖ Magnetic brew basket sensor
 - ❖ Brew basket safety locks
 - ❖ Brew temperature protection
-

Specifications

Requirements

- ❖ **Water Requirements:**
 - CBS-2041: 20-75 psig, 1 gpm
 - CBS-2042: 20-75 psig, 1 ½ gpm
- ❖ **Electrical:** See electrical configuration chart.
- ❖ **Coffee Filters:** 13" X 5" FETCO Product # F002

Electrical Configuration and Brewing Efficiency

US & Canada

CBS-2041

1.0 gallon per batch

Electrical Config. Code	Heater Configuration	Voltage (AC)	Phase	Wires	KW	Maximum Amp draw	Batches per Hour* (max 11)	
							Cold Water	Hot Water
E41046 Can be connected to 120 VAC or 120/208-240 VAC	1 X 1.5 KW	120	single	2 + ground	1.6	13.0	3.8	9.3
	2 X 1.5 KW	120/208	single	3 + ground	2.4	11.3	5.8	11.0
		120/220			2.6	12.0	6.5	11.0
		120/240			3.1	13.0	7.7	11.0
E41036 Can be connected to 120 VAC or 120/208-240 VAC	1 X 1.7 KW	120	single	2 + ground	1.8	14.7	4.4	10.5
	2 X 1.7 KW	120/208	single	3 + ground	2.7	12.8	6.5	11.0
		120/220			3.0	13.5	7.3	11.0
		120/240			3.5	14.7	8.7	11.0
E41016 Can be connected to 120 VAC or 120/208-240 VAC	1 X 2.3 KW	120	single	2 + ground	2.4	19.7	5.9	11.0
	2 X 2.3 KW	120/208	single	3 + ground	3.6	17.1	8.9	11.0
		120/220			4.1	18.1	9.9	11.0
		120/240			4.7	19.7	11.0	11.0

CBS-2042

1.0 gallon per batch

Electrical Config. Code	Heater Configuration	Voltage (AC)	Phase	Wires	KW	Maximum Amp draw	Batches per Hour* (max 22)	
							Cold Water	Hot Water
E42016	2 X 3 KW	120/208	single	3 + ground	4.6	22.4	11.5	22.0
		120/220			5.1	23.7	12.9	22.0
		120/240			6.1	25.8	15.4	22.0

* Based on standard factory settings: 4.0 minute brew time; 0% prewet; 200 F water.

Export

CBS-2041

1.0 gallon per batch

Electrical Config. Code	Heater Configuration	Voltage (AC)	Phase	Wires	KW	Maximum Amp draw	Batches per Hour* (max 11)	
							Cold Water	Hot Water
E41026	1 X 3 KW	220	single	2 + ground	2.6	12.0	6.5	11.0

CBS-2042

1.0 gallon per batch

Electrical Config. Code	Heater Configuration	Voltage (AC)	Phase	Wires	KW	Maximum Amp draw	Batches per Hour* (max 22)	
							Cold Water	Hot Water
E42026	2 X 3 KW	220	single	2 + ground	5.1	23.7	12.9	22.0

* Based on standard factory settings: 4.0 minute brew time; 0% prewet; 200 F water.

Dimensions & Utility Connections

CBS-2041

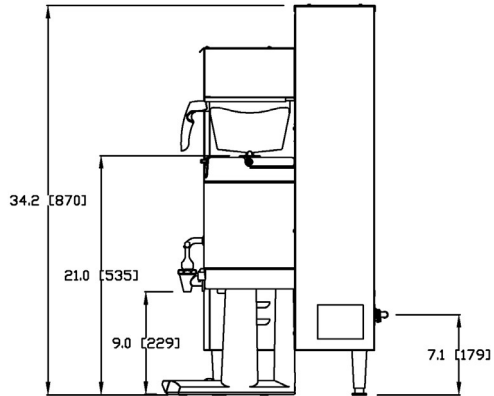
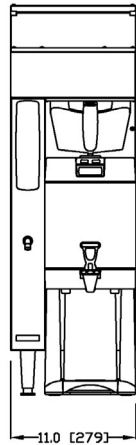
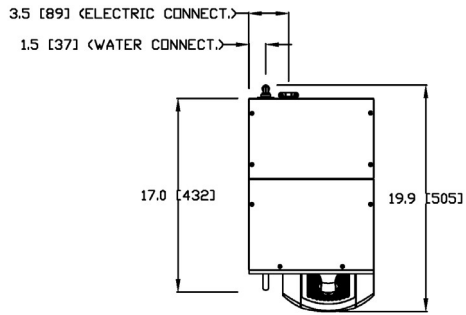

CBS-2042

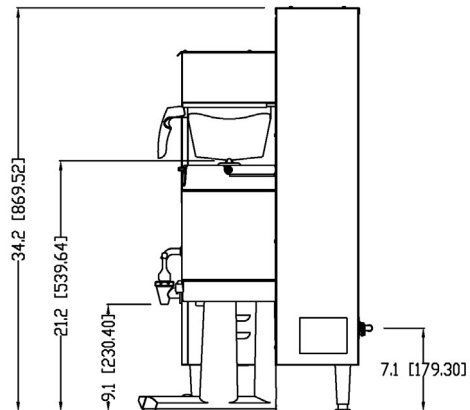
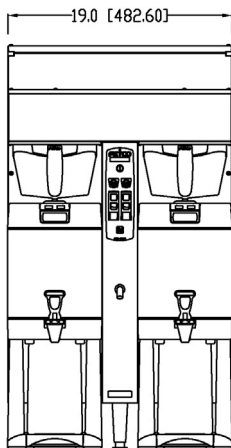
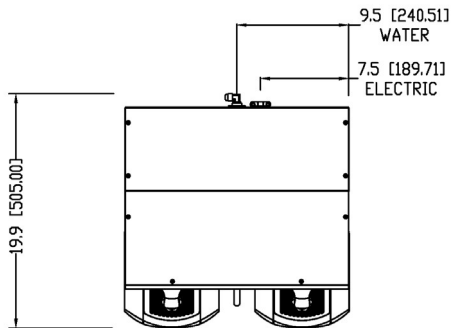

Installation

(For Qualified Service Technicians Only)

Keys To A Successful Installation

If not installed correctly by qualified personnel, the brewer will not operate properly and damage may result. Damages resulting from improper installation are not covered by the warranty.

Here are the key points to consider before installation:

Electrical:

- ❖ All FETCO brewers require **NEUTRAL**. Ground is not an acceptable substitute. Installation without neutral may cause damage to the electronic components.
- ❖ The electrical diagram is located on the inside of the lower cover.
- ❖ The installation must comply with applicable federal, state, and local codes having jurisdiction at your location. Check with your local inspectors to determine what codes will apply.

Plumbing:

- ❖ This equipment is to be installed to comply with the applicable federal, state, or local plumbing codes.
- ❖ The water line must be flushed thoroughly prior to connecting it to the brewer to prevent debris from contaminating the machine.
- ❖ Verify that the water line will provide at least $\frac{1}{4}$ gallon per minute for the CBS-2041, and $\frac{1}{2}$ gallons per minute for the CBS-2042 before connecting it to the brewer.

General:

- ❖ Utilize only qualified beverage equipment service technicians for installation. A Service Company Directory may be found on our web site, <http://www.fetco.com>.

Installation Instructions

Brewer Setup

1. Review the Dimensions for the unit you are installing. Verify that the brewer will fit in the space intended for it, and that the counter or table will support the total weight of the brewer and dispensers when filled.
2. The brewer's legs are shipped inside the brew baskets. Remove the brew basket(s) and the coffee dispenser(s). Place the brewer on its back and screw in the legs.
3. Place the brewer on the counter or stand.
4. When the brewer is in position, level it front to back as well as side to side by adjusting the legs.
5. Remove the lower cover to access the water and electrical connections. Knock-outs are provided in the back and base of the brewer body for the connections.



Warning: Legs are to be adjusted for leveling the brewer only. Do not use for height adjustment or extend them higher than necessary.

Water Connection

1. Water inlet is a $\frac{3}{8}$ inch male flare fitting.
2. The brewer can be connected to a cold or hot water line. Cold water is preferred for best coffee flavor, but hot water will allow for faster recovery times.
3. Install a water shut off valve near the brewer to facilitate service. If an in-line water filter is used, it should be installed after the water shut off valve and in a position to facilitate filter replacement.
4. Flush the water supply line and filter **before** connecting it to the brewer.
5. Verify that the water line will provide at least $\frac{1}{4}$ gallon per minute for the CBS-2041, and $\frac{1}{2}$ gallon per minute for the CBS-2042, and that the water pressure is between 20 and 75 psig.

Electrical Connection – US & Canada

1. Verify that the actual voltage at the electrical service connection is compatible with the specifications on the brewer’s serial number label. Make sure the electrical service includes **neutral**.
2. The temperature and water tank fill level are pre-set at the factory. There is no need to turn off the heaters during the installation process. The heaters are disabled by the control board until the tank is full of water. The heating process will start automatically when the tank has filled.
3. The CBS-2041 is factory equipped with a 120 V cord and plug. The CBS-2042 has only a terminal block for connecting the incoming power wires. Consult local codes to determine if a cord and plug can be installed, or if the unit must be hard wired.
4. A fused disconnect switch or circuit breaker on the incoming power line must be conveniently located near the brewer, and its location and markings known to the operators.
5. The body of the brewer must be grounded to a suitable building ground. A ground lug is provided in the brewer next to the power terminal block. Use only 10 gauge copper wire for grounding.
6. Electrical connections must be secured in-place within the unit to meet national and local standards.
7. Finally, connect the incoming power wires to the terminal block as shown in accordance with applicable codes.

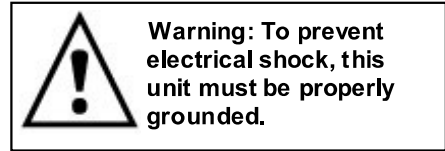

CBS-2041

This model can be connected to 120 VAC or 120/208-240 VAC

Factory Configuration
120 VAC, 3 wires

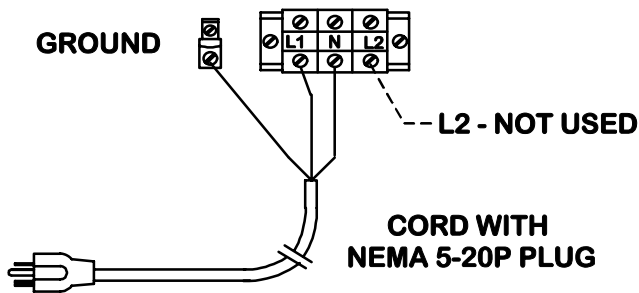

Optional Field Conversion*
120/208-240 VAC, 4 wires

- Step 1: Remove the factory provided 120 V cord & plug from the terminal block.
- Step 2: Connect the incoming wires to the terminal block in accordance with applicable codes.

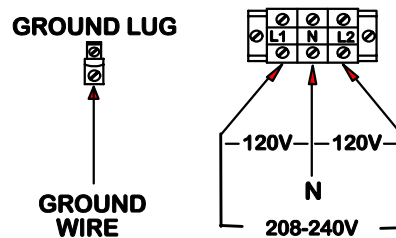

**This procedure must be performed only by a qualified service technician.*

Notice: In order for this product to comply with the requirements of the Underwriters Laboratories listing, the following conditions apply:

- 1.) This unit must be hard wired for 120/208-240 VAC.
- 2.) Once the unit is converted to 120/208-240 VAC operation, it cannot be converted back to 120 VAC operation.

CBS-2042

This model can be connected only to 120/208-240 VAC

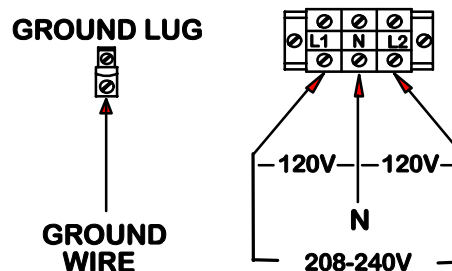

Final Setup

1. Turn on the incoming water supply line and inspect both inside and outside of the brewer for leaks in all fittings and tubes
2. Turn on the incoming power.
3. Press the brewer's main power switch, which is hidden behind the front leg of the brewer. The control panel on/off switch will begin flashing. Press this switch.
4. Within 6 seconds, the hot water tank will begin filling until the water is sensed by the probe at the top of the tank. The display will read "FILL". The heaters will be disabled by the control board until the tank is full.
5. While the water is heating, the display will read "LO". Once the temperature has reached 175°F, the actual water temperature will also be displayed. After the water has reached the set temperature, the display will be blank. There is no "ready" light.
6. Review the Operating Instructions. Brew one full batch (water only) on each side to confirm proper fill levels. The brewer is factory set with water only (no coffee) to dispense the correct amount of water. If the actual volume is slightly different from the programmed volume, fine tuning the brewer may be necessary. See #60 – 61 in the Advanced Settings & Diagnostics section.
7. Re-attach the covers after one final inspection for leaks. Look closely in the top of the brewer at the dispense fittings during this inspection.

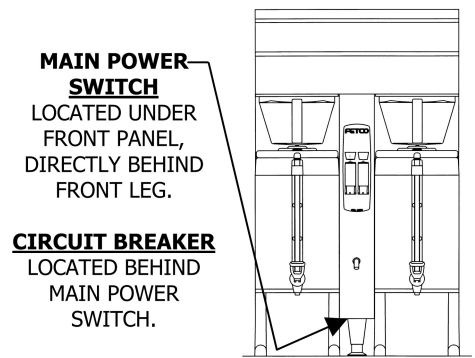

Operator Training

Review the operating procedures with whoever will be using the brewer. Pay particular attention to the following areas:

1. Always pre-heat the dispensers before the first use of each day by filling them half way with hot water, and letting them stand for at least 15 minutes.
2. Don't remove the brew basket until it has stopped dripping.
3. Make sure the dispenser is empty before brewing into it.
4. Show how to attach covers, close, and or secure the thermal dispensers for transporting.
5. Show the location and operation of the water shut off valve as well as the circuit breaker for the brewer.
6. Steam from the tank will form condensation in the vent tubes. This condensation will drip into and then out of the brew baskets. 1/4 cup discharging overnight is possible. Place an appropriate container under each brew basket when not in use.
7. We recommend leaving the power to the brewer on overnight. The water tank is well insulated and will use very little electricity to keep the tank hot. Leaving the brewer in the on position will also avoid delays at the beginning of shifts for the brewer to reach operating temperature.

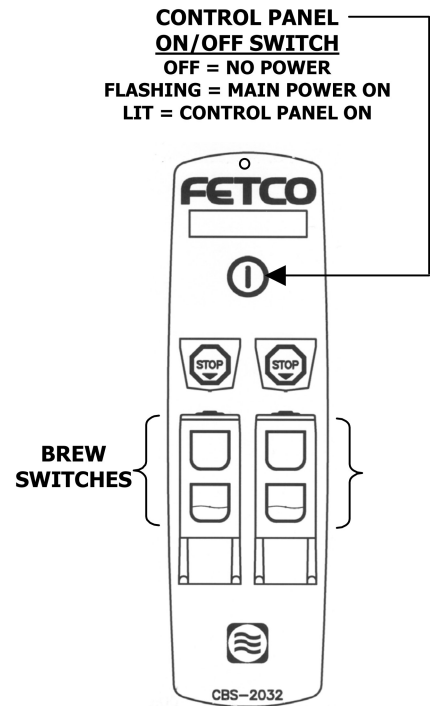

Operating Instructions

Control Panel Functions

Only switches that are active are illuminated.

Switches that are inactive or disabled are invisible.

1 Main Power Switch

- Controls all power to brewer
- Indicator lamp at top of panel.

2 Control Panel On/Off Switch

- Affects only control panel. Does not disconnect main power.
- Flashing = Off
- Lit = On
- Invisible = Main Power Off

3 Display

- "FILL" = Water tank is filling.
- "LO XXX" = Unit is heating, not ready to brew. (XXX = actual temperature, if over 175°F)
- Blank = Ready to brew.
- Also displays error messages.

4 Stop Switches

- Stops brew cycle
- Lit = Brew cycle in progress
- Invisible = Not brewing, or dripping in progress

5 Brew Switches

- Starts brew cycle
- Must be held in for 1 second
- Flashing = Brew cycle in progress
- Lit = Ready to brew
- Invisible – Not ready to brew, or batch disabled (See Programming Section)

6 Hot Water Switch

- Dispenses hot water from faucet
- Hold in to dispense

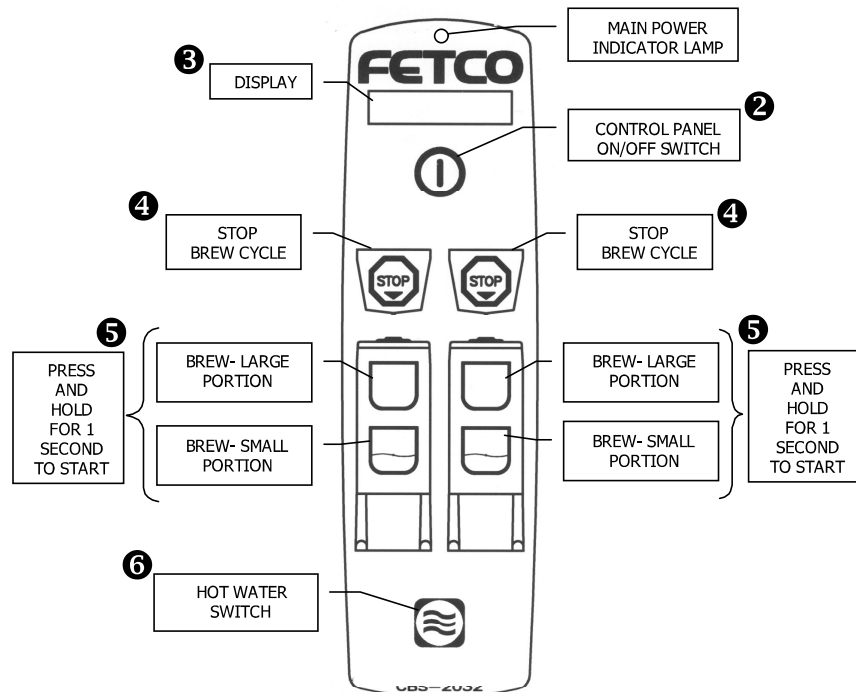
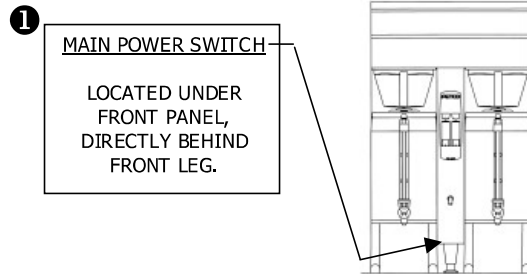

Brewing

1. Turn the main power switch and control panel switch on.
2. Prepare a brew basket with the correct size filter and appropriate amount of coffee.
3. Slide the brew basket completely into the rails.
4. Place a clean, empty, preheated dispenser under the brew basket.
5. Select a batch from the available choices, and hold the corresponding BREW button in for 1 second to start the brew cycle.
6. The STOP button will illuminate, and the selected BREW button will flash, indicating that brewing is in progress. All other BREW buttons will extinguish.

7. When the brew cycle is finished, the STOP button will extinguish and the BREW button will continue flashing, indicating that coffee may still be dripping from the bottom of the brew basket.
8. Before removing the brew basket or dispenser, visually verify that dripping has stopped.

Notes:

- Preheat dispenser by filling at least ½ full with water at brewing temperature. Allow it to sit for at least 15 minutes before draining.

Programming

Batch Settings

- ❖ Turn the brewer off by pressing the main power switch.
- ❖ Press the main power switch again to turn the unit on.
- ❖ Quickly hold the **STOP** button for 3 seconds.
- ❖ The display will show the software version for 3 seconds. Example: **0.0 2.11**
- ❖ Batches are numbered 1 – 2 (CBS-2041) or 1 – 4 (CBS-2042)

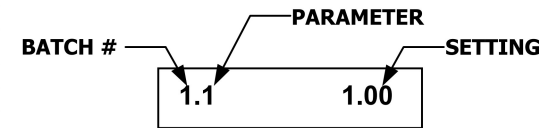
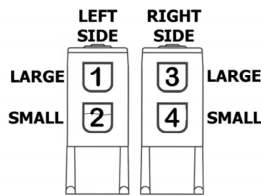

Example: Left Side – Large Batch – Brew Volume 1.0 Gal.

- ❖ Next, the first batch parameter is displayed – batch 1, brew volume
Use the **SCROLL UP** and **SCROLL DOWN** buttons to adjust.
Press the **STOP** button to go to the next parameter – brew time.
- ❖ Continue this way until all parameters are programmed for batch #1.
(See the chart below for an explanation of each parameter.)
- ❖ Next, batch #2 programming begins.
Batches 2 and 4 may be disabled by leaving them set to “OFF”.
Change to “ON” to enable. Batches 1 and 3 cannot be disabled.
- ❖ After all batches are programmed, go to temperature settings.

Display

S t b y

P r G

0.0 2.11

1.1 1.00

1.2 4.00

2.0 OFF

7 200

(See next page)

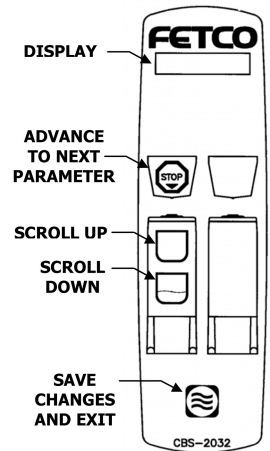
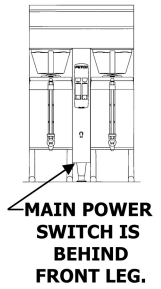

Important! After programming, you must press the **HOT WATER** button to save the settings and exit programming mode, or changes will be lost. You may exit programming at any time.

Batch Parameters

X=Batch Number (1 - 4)					
Parameter	Name	Range	Increment	Default Setting	Comment
X.0	Batch Enabled or Disabled	On/Off		Batch 1 & 3 = ON Batch 2 & 4 = OFF	Batch 1 & 3 cannot be disabled.
X.1	Brew Volume (Gallons)	0.25 – 1.25	0.01	1.0 gallons	To display liters, see # 59 in Advanced Settings section.
X.2	Brew Time (Min:Sec)	2:00 – 24:00	0:30	4:00 minutes	
X.3	Bypass Percent	0.00 – 40.0%	1%	0 %	Percentage of total brew volume
X.4	Prewet Percent	0.00 – 15.0%	1%	0 %	Percentage of total brew volume
X.5	Prewet Delay (Min:Sec)	0:10 – 5:00	0:10	1:00 minute	The time between prewetting and start of brew cycle.
X.6	Drip Delay (Min:Sec)	0:30 – 6:00 Minutes	0:10	1:30 minute	The time between end of brew cycle and unlocking of brew basket.

Temperature Settings

Parameter	Name	Range	Default Setting	Comment
7	Water Temp. (°F)	180°F - 208°F	200°F	Inside tank. Will be slightly lower at spray head. To display in ° Celsius, see # 58 in Advanced Settings.
8	Hot Water Service	A (auto) / On / Off	A (auto)	A= Faucet will dispense only when not brewing. On=Faucet always enabled. Off=Faucet always disabled.
9	Brew at Set Temperature	0 - 1	1	0=Will brew at any temperature. 1=Will brew only at set temperature. Note: Changes will not take effect until the next brew cycle is completed.

Parameter	Name	Range	Default Setting	Comment
10	Enter Advanced Settings & Diagnostics	0 - 1	0	0 = Skip Advanced Settings & Diagnostics. Loop back to start of batch programming cycle. 1 = Enter Advanced Settings & Diagnostics.

Important! To save your changes, press  to exit programming mode and return to operating mode.

Advanced Settings and Diagnostics

Address	Description	Range	Default	Comment
50	Water Level in Tank	0 - 1		Tests if water is touching probe. 0 = Tank is less than full 1 = Tank is full
51	Water Resistance			Water resistance (ohms) as read by probe.
52	Brew Basket Sensor State (left / right)	0 - 1		To test, slide the brew basket in and out. Display should toggle between 0 and 1. 0 = Brew basket in. 1 = Brew Basket out.
53	Power Relay State	0 - 1		Checks power relay on control board. To test, press Control Panel Power Switch. Display should toggle between 0 and 1. 0 = Power relay OFF, switch should blink. 1 = Power relay ON, switch should be lit..
54	N/A			Not used on this model.
55	Tank Temperature	180°F - 208°F		Displays current tank temperature. If temperature is below 175°F, displays "LO".
56	Circuit Board Configuration			Should read 000 for CBS-2041 001 for CBS-2042
57	Reload Defaults	0 - 1	0	Changes all settings to default factory settings. 0 = Do not reload defaults 1 = Reload all default settings If 1 is selected, you must advance to the next address for this change to take effect.
58	Temperature Scale	F or C	F	F = Displays temp in degrees Fahrenheit C = Displays temp in degrees Celsius
59	Water Volume Scale	GAL or LTR	GAL	GAL = Displays volume in gallons LTR = Displays volume in liters

Address	Description	Range	Default	Comment
60 and 61	Left Brew Valve Flow Rate Right Brew Valve Flow Rate	0.30 – 0.50 <i>If #59 is GAL</i> or 1.13 – 1.89 <i>If #59 is LTR</i>	0.40 1.51	Use this to compensate for minor discrepancies in actual volume versus programmed volume. Set lower to increase volume, higher to decrease volume. The following formula can be used to determine the correct setting: $\frac{\text{ACTUAL VOLUME}}{\text{PROGRAMMED VOLUME}} \times \text{CURRENT SETTING} = \text{NEW SETTING}$
62 and 63	Left Bypass Valve Flow Rate Right Bypass Valve Flow Rate	0.28 – 0.38 <i>If #59 is GAL</i> or 1.05 – 1.44 <i>If #59 is LTR</i>	0.33 1.24	
64	Keypad Test	0 - 1	0	Tests function of control panel switches. 0 - Skip keypad test 1 - Keypad test active Starting at the top, press each button. Display will read the name of the switch being pressed. Brew switches are named S1, S2, S3, etc. The hot water switch must be pressed last, as this will exit the test.
65	Relay Test	0 - 1	0	0 - Skip relay test. Loop back to #50 1 - Relay test active. Go to #90

Press  to save the settings and exit Diagnostic mode.

Press  again to exit Programming mode and return to Operating mode.

Relay Test

Tests the individual relays which control various components.
Use either batch button to actuate the relays.

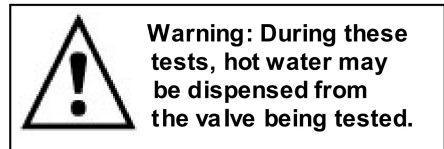

To begin, you must first press the blinking Control Panel Power Switch.

Address	Description	Comment
90	Left or Single Brew Valve	
91	Right Brew Valve	
92	Left or Single Bypass Valve	
93	Right Bypass Valve	
94	Hot Water Faucet	
95	Fill Valve	
96	Heater	To protect the heaters, this test will work only if the tank is full.
97	Left or Single Brew Basket Lock	
98	Right Brew Basket Lock	

Press  to exit Relay Test.

Press  again to exit Diagnostic mode.

Press  again to exit Programming mode and return to Operating mode.

Error Codes

Code	Description	Possible Cause	Corrective Action	How to Clear Error Codes	
				Software Ver. 1.51 and lower	Software Ver. 2.0 and higher
001	Internal Error System had to reload default settings.	Control board failure.	Clear error. Re-program the brewer to the desired specifications. If error occurs again, replace control board.	Enter programming mode, then exit programming mode.	Turn main power switch off and on.
002	Power Failure Power state does not match feedback loop state.	Relay on control board has failed.	Replace control board.	Enter programming mode, then exit programming mode.	Turn main power switch off and on.
050	Shorted temperature probe.	Probe failure.	Replace probe.	Enter programming mode, then exit programming mode.	Turn main power switch off and on.
051	Open temperature probe.	Bad probe connection, or probe failure.	Check all connections. Replace probe if necessary.	Enter programming mode, then exit programming mode.	Turn main power switch off and on.
100	Initial Fill Error Initial fill time was more than 8.6 minutes.	Water supply flow rate is too low.	Watch for short potting during brew cycle. Investigate cause of low flow rate. (Clogged water filter, etc.)	Press the control panel power switch.	Press the control panel power switch.
101	Error on refill Tank did not refill within 2 minutes.	Water supply flow rate is too low.	Watch for short potting during brew cycle. Investigate cause of low flow rate. (Clogged water filter, etc.)	Error message is cleared automatically at end of brew cycle.	Error message is cleared automatically at end of brew cycle.
102	Unwanted Fill When brewer is idle, the fill valve was activated for more than 30 seconds during a 1 hour period.	Possible leak in tank, fitting, or valve.	Check inside of machine for leaks.	Enter programming mode, then exit programming mode.	Turn main power switch off and on.
		Output on control board has failed, causing a dispense valve to open.	Replace control board.		
200	Flat Line Temperature (Water is boiling) System is calling for heat, but the temperature does not rise at least 2°F within 5 minutes.	Mercury relay is stuck closed, bad output on control board, or temperature is set too high for altitude.	Check mercury relay, check control board output, or adjust temperature for altitude.	Enter programming mode, then exit programming mode.	Turn main power switch off and on.

201	Heater Open System is calling for heat, but the temperature does not rise at least 2°F within 10 minutes. This error is disabled during brewing and while using the hot water faucet.	Heating element failure.	Check and replace heating elements if necessary.	Enter programming mode, then exit programming mode.	Turn main power switch off and on.
202	Heater Short System is not calling for heat, but temperature rises more than 5°F.	Possible mercury relay stuck closed, or bad output on control board.	Check mercury relay and control board.	Enter programming mode, then exit programming mode.	Enter programming mode, then exit programming mode.
255	Keypad Error A switch was pressed for more than 45 seconds.	Switch was held in too long, or switch is stuck closed.	Clear error and try again. If error occurs without switch being pressed, replace input board.	Enter programming mode, then exit programming mode.	Turn main power switch off and on.

Service

Utilize only qualified beverage equipment service technicians for service. A Service Company Directory may be found on our web site, <http://www.fetco.com>. Companies listed as “Extractor Authorized” stock parts for these models.

When changing the control board, check the software version on the chip. Example- V2.11. If the chip on the replacement board has an older software version than the board being replaced, carefully remove the chip from the old board and place it in the new board. Use a chip puller if one is available.

Cleaning & Maintenance

Daily: Wipe the area above the brew basket to remove coffee residue.

Daily or Weekly: The spray plate should be removed and cleaned to remove hard water deposits. In areas with extremely hard water, it may be necessary to do this daily. Weekly cleaning may be sufficient in some areas.

When cleaning the spray plate, make sure that each hole is completely free of mineral deposits. A toothpick may be used for cleaning out the holes. Never use metal objects or abrasives on the spray plate’s Teflon coating.

See separate instructions for cleaning LUXUS L3D Dispensers.

Wiring Diagrams

CBS-2041

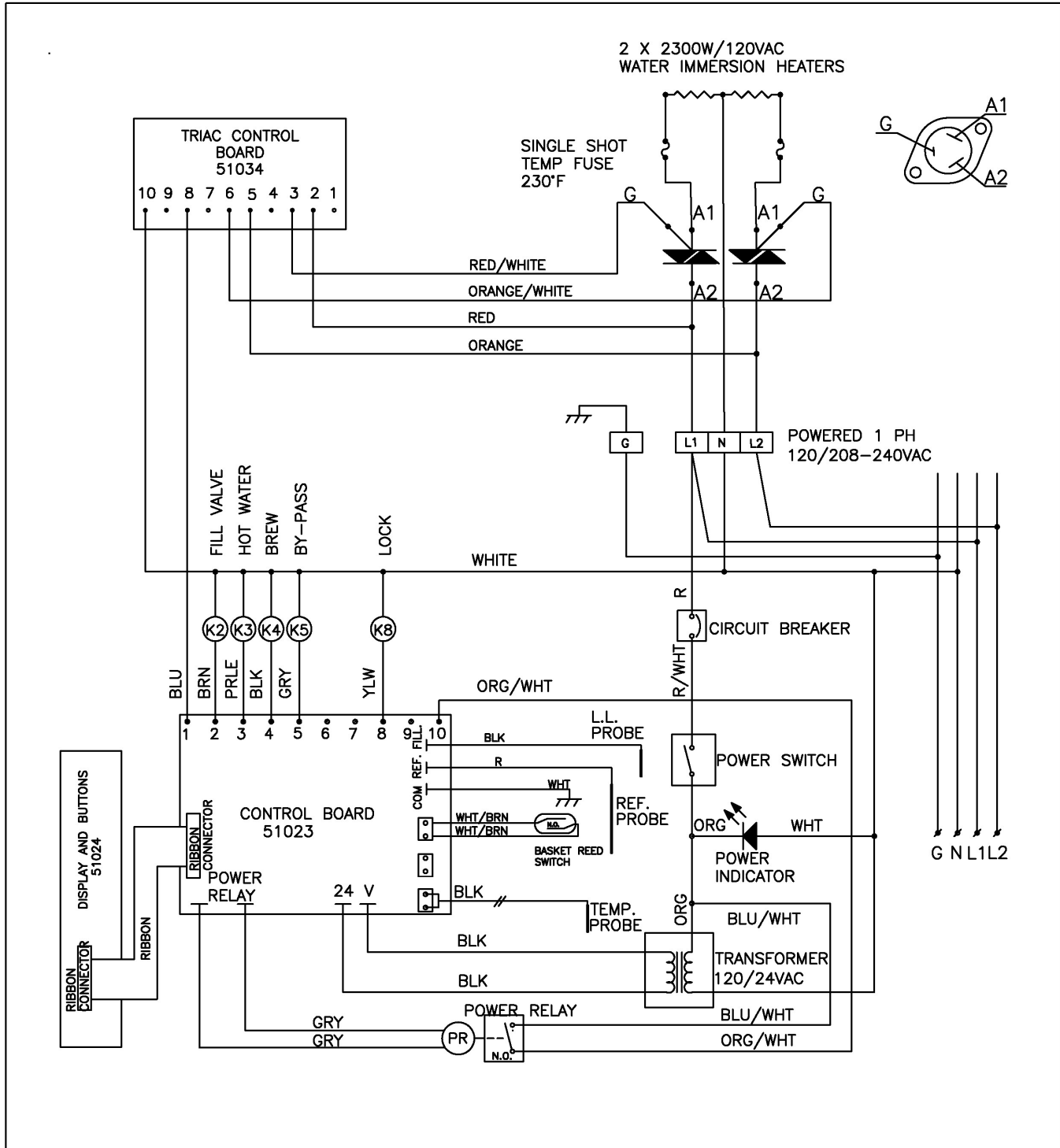

FETCO FOOD EQUIPMENT TECHNOLOGIES COMPANY, INC.
 640 HEATHROW DRIVE, LINCOLNSHIRE, IL, 60069, USA.
 PHONE: (800) 338-2699, (847) 821-1177
 e-MAIL: techsupport@fetco.com, http://www.fetco.com

FETCO PRODUCT NO.
CBS-2041

DESCRIPTION
120/208 - 240VAC, 1PH, 3 WIRE + GRD

WIRING DIAGRAM NO.
401174-001

CBS-2042

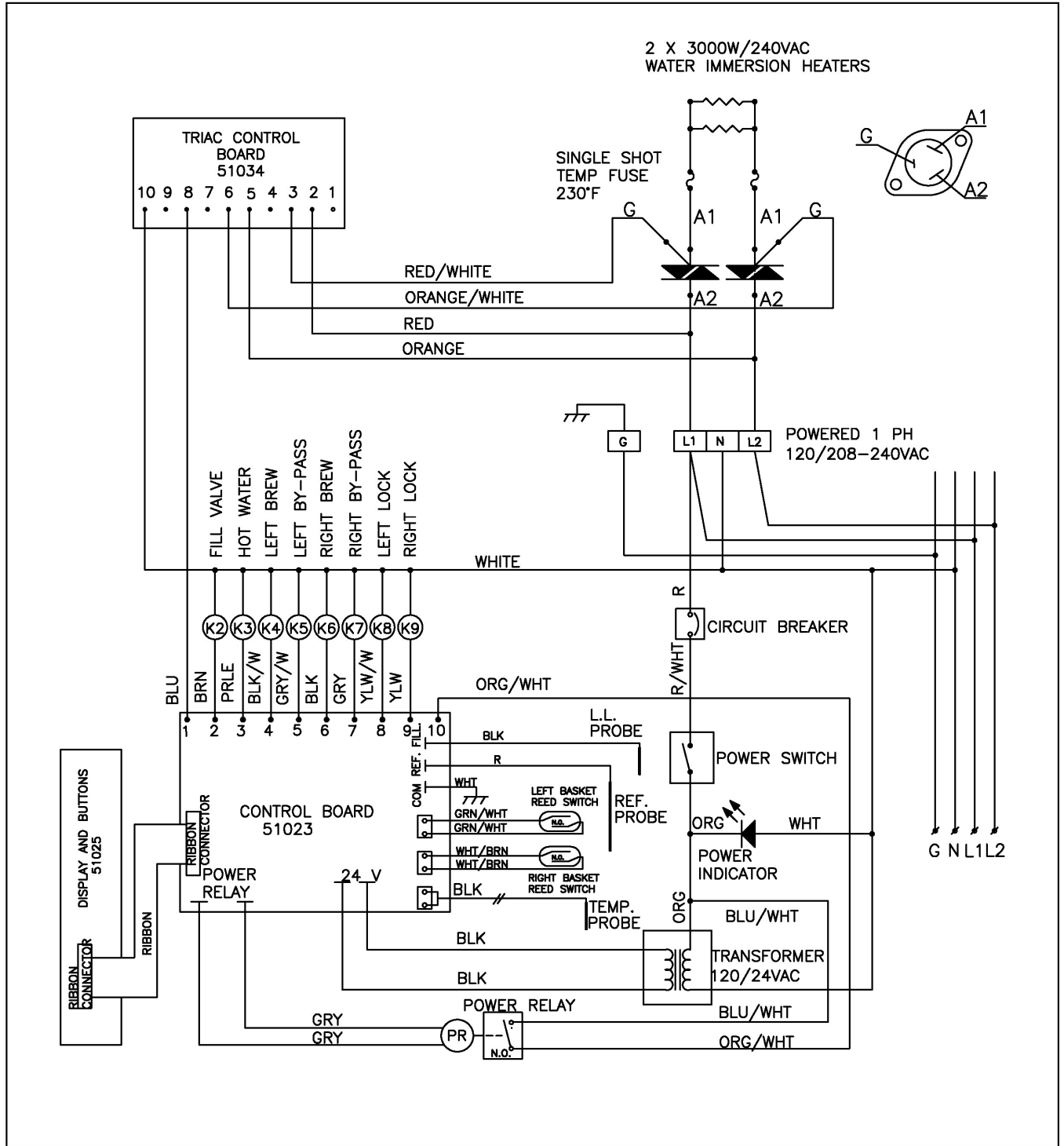

FETCO FOOD EQUIPMENT TECHNOLOGIES COMPANY, INC.
 640 HEATHROW DRIVE, LINCOLNSHIRE, ILL. 60069, USA.
 PHONE: (800) 338-2699. (847) 821-1177
 e-MAIL: techsupport@fetco.com. http://www.fetco.com

FETCO PRODUCT NO.	DESCRIPTION	WIRING DIAGRAM NO.
CBS-2042	120/208 - 240VAC, 1PH, 3 WIRE + GRD	401176-002

Parts

Main assembly and tank assembly drawings were not available at time of publication.

Figure 3 – Spray Housing Assembly – CBS-2041 & CBS-2042

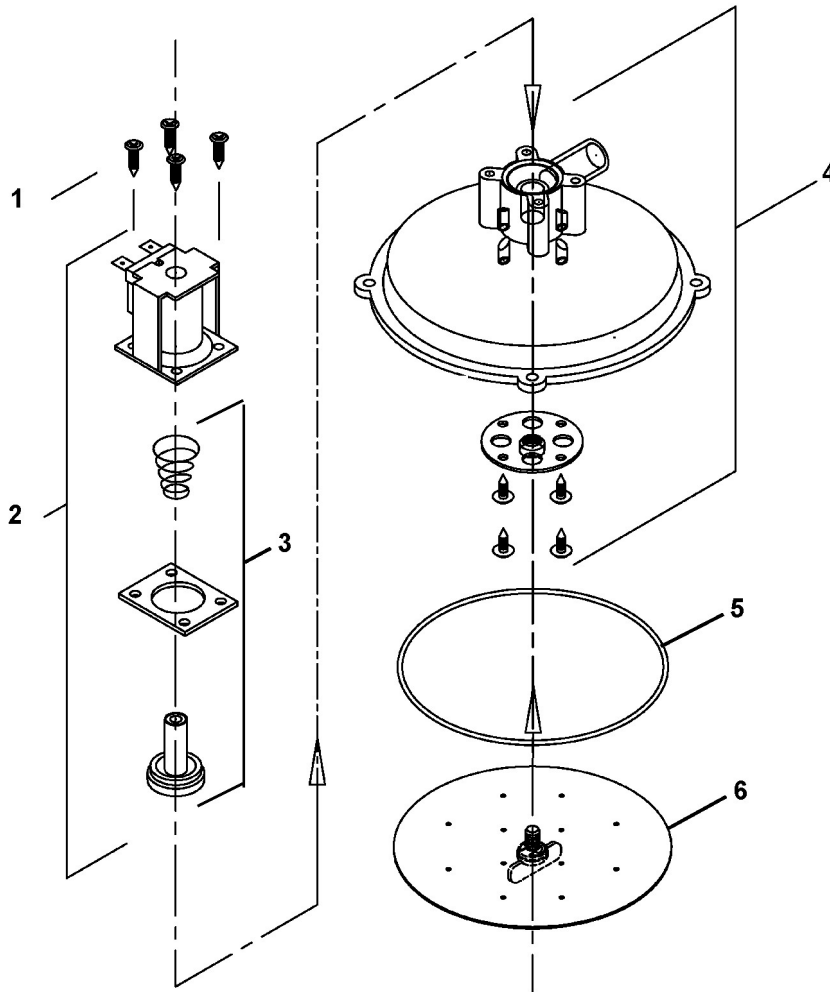

ITEM #	QTY	PART NO	DESCRIPTION
1	4	82112	#8 X 3/4" PAN HD. PHIL. T.S. 18-8 S.S. SCREW
2	1	57047	COIL ASSY. REPAIR KIT, DSV-11, 120 VAC
2	1	57071	COIL ASSY. REPAIR KIT, DSV-11, 240 VAC (EXPORT VERSION ONLY)
3	1	57073	VALVE REBUILD KIT, DSV11
4	1	102082	SPRAY HOUSING ASSY.
5	1	24054	O-RING 4.237" I.D., #156
6	1	102081	SPRAY PLATE ASSY., 4 7/8" DIA.

Figure 4 – Brew Basket Assembly, 13" X 5", Part # 101175

ITEM	QTY	PART #	DESCRIPTION
1		09022	WIRE INSERT, 13" X 5
2	1	23117	BREW BASKET HANDLE, BLACK
3	1	46011	WARNING LABEL
5	1	82096	HANDLE SCREW
8	1	57082	MAGNET
NOT SHOWN		F002	PAPER FILTERS, 13" X 5" 500 PER CASE

COLOR BREW BASKET HANDLES

PART #	DESCRIPTION
23106	BREW BASKET HANDLE, GREEN
23107	BREW BASKET HANDLE, ORANGE
23148	BREW BASKET HANDLE, RED

